

# Speed Pulleys

Versatile rehabilitation and speed training exercises. Pulleys are available in BLACK or GREY

- 1 \_\_\_\_\_
- 2 \_\_\_\_\_
- 3 \_\_\_\_\_

Speed pulley 50kg



Main features of speed pulleys:

1. Possibility of starting with low weight and setting the weight precisely using one or two ropes
2. Not losing the weight even when doing explosive speed exercises
3. You are able to do different (speed) exercises like running with extra resistance, throwing motions and skiing exercises - even with two hands

Speed pulleys allow exercises according to speed variation but are not limited to only those. By moving faster the resistance is a little higher making the exercise a little bit more difficult to perform. You can also do the same exercises as with standard pulleys but the combination of long ropes and two handles enable a variety of different exercises – the only limit is your own imagination. For example you can use one handle for the exercise and the other one for stabilization and core training.

The extremely smooth pulling mechanism of Lojer Speed pulleys allow even explosive exercise movements – without losing or jolting the weight. Speed pulleys have a very light weight stack - you can start from 500 gram resistance. You can also double the weight by connecting both ropes to one handle. Speed pulleys feature two adjustment pins: first one for adjusting the height of the rope and the second one acts as a range motion limiter. By pulling the rope one meter, the weight stack rises only about 20 cm. This enables different motion speed exercises like running with extra resistance, throwing motions et cetera.

**Mobile speed pulley** is the best option for limited space or when wall-attachment cannot be used. It is also an excellent option for rehabilitation that takes place f.ex.in rehabilitation wards. The mobile speed pulley features a 50 kg encased weight stack, casters and two ropes with handles. Both models available in black or grey.

**LOJER**® For easy care

## Technical specifications

	Speed pulley 50kg	Speed pulley 80kg	Speed pulley 100kg	Mobile speed pulley
Weight stack	50 kg	80 kg	100 kg	50 kg
Weight plates	20 x 2,5 kg	16 x 5 kg	20 x 5 kg	20 x 2,5 kg
Colour	Black/ Grey	Black/ Grey	Black/ Grey	Black/ Grey
Max. length of ropes using 1 rope (halved with 2 ropes)	12 meters	11,5 meters	11 meters	7,5 meters
Overall height	230 cm	217 cm	217 cm	186 cm
Width	29,5 cm	51 cm	51 cm	74,5 cm
Depth with adjustment pins	32 cm	54 cm	54 cm	77 cm
Total weight	81 kg	154 kg	174 kg	85 kg
Casters	-	-	-	Ø75 mm   central locking
CE-marked	Yes	Yes	Yes	Yes
Warranty (years)	Steel parts 10 mechanism 2	Steel parts 10 mechanism 2	Steel parts 10 mechanism 2	Steel parts 10 mechanism 2
Country of Manufacture	Finland	Finland	Finland	Finland

## Resistance matrix for Speed pulley 50 kg and Mobile speed pulley

The Lojer speed pulley resistance ratio with one rope is 1 : 5 and with two ropes 2 : 5. Check the matrix below for more information and examples.

Weight pin №	Weight of the plate(s) total	Total outcoming resistance with one handle	Total outcoming resistance with two handles
1	2,5 kg	0,5 kg	1,0 kg
2	5, 0 kg	1,0 kg	2,0 kg
5	12,5 kg	2,5 kg	5,0 kg
10	25,0 kg	5,0 kg	10,0 kg
20	50,0 kg	10,0 kg	20,0 kg

## Resistance matrix for Speed pulley 80 kg and 100 kg

Weight pin №	Weight of the plate(s) total	Total outcoming resistance with one handle	Total outcoming resistance with two handles
1	5 kg	1 kg	2 kg
2	10 kg	2 kg	4 kg
5	25 kg	5 kg	10 kg
10	50 kg	10 kg	20 kg
16	80 kg	16 kg	32 kg

## Accessories:

- Training glove/ 210050
- Triceps rope/ 2512126
- Triceps rod straight rubber/ 13107
- Rowing handle/ 402024
- Gantry for Mobile Speed Pulley/ 15106TL
- Gantry for Speed Pulley 50kg/ 15106T
- Gantry for Speed Pulley 80/100kg/ 15106T100
- Support handle Lojer pulley/ VH8083
- Support handle Lojer pulley+gantry/ VH80831
- Handle for vertical pulley Lojer/ VD6800
- Strap padded ankle 25x8 cm/ 402020
- Strap padded thigh/shoulder/ 402021
- Strap padded waist/ 402022
- Rotation strap with padding/ 402025
- Leather strap wrist 32x5 cm/ 402029
- Leather strap ankle 62x5 cm/ 402030
- Leather strap 124x8 cm/ 402032
- Leather strap Maxi ankle/ 402033
- Head strap/ 402034
- Strap padded ankle with velcro lock/ 402040

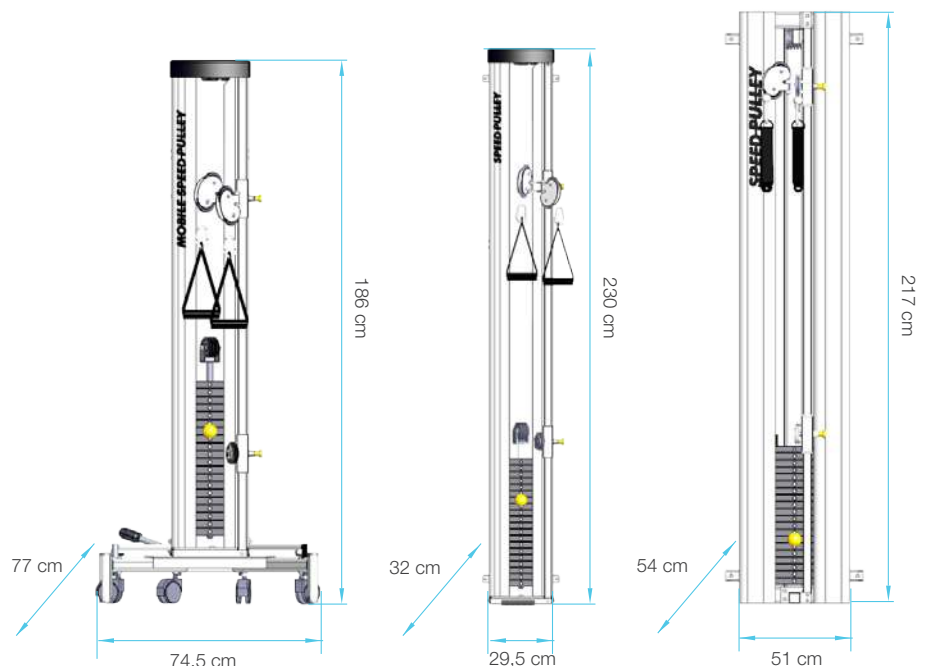

**LOJER**® For easy care